

# CNC machine

with servomotor drive

**EUROMOD** **isel**® France



**EuroMod MP 30** with closed sliding door

## Technical specification

	<b>EUROMOD</b> MP 30	<b>EUROMOD</b> MP 45	<b>EUROMOD</b> MP 65
<b>Traverse path X/Y/Z [mm]</b>	650/300/250	650/450/250	1000/650/250
<b>Clamping table surface W×D [mm]</b>	900x350	900x500	1200x700
<b>Throughput [mm]</b>	350		
<b>Dimensions W × D × H [mm]</b>	1160x800x1700	1160x1110x1700	1480x1510x1700
<b>Processing speed X/Y/Z</b>	appr. 250 mm/s		
<b>Repeatability [mm]</b>	± 0,02		
<b>Drive motors</b>	48V servomotors		
<b>Drive elements X/Y/Z</b>	Recirculating ball drive, clearance free adjustable		
<b>Controller</b>	iMD CAN controller with 3 drive controllers, expandable to 12 axes (max. 6 interpolated & 6 handling axes), PC, I/O module, safety circuit with rest state monitoring, power supply unit 48V/1000 W		
<b>Operation</b>	19" CNC control panel with touch screen, keyboard and mouse		
<b>Weight [kg]</b>	appr. 250	appr. 280	appr. 375
<b>Software</b>	Windows, WinRemote (optional: ProNC, isy 2.5 PLUS)		
<b>Connection values</b>	230V, 16A		
<b>Part no.</b>	<b>275133 33665</b>	<b>275143 33665</b>	<b>275153 33665</b>

\* without mounted components on the axes.

# CNC machine

## with servomotor drive

**EUROMOD<sup>®</sup>**

### General note

The choice of the ideal CNC machine for you should focus both on the clamping area for the workpiece, materials or plates to be machined and on the strategy or difficulties of the machining. In principal, all machines are perfectly suited for machining light metals, non-ferrous metals, plastics and wood . Extensive range of accessories for all our CNC machines to order (see page E18 et seq.).

### Options

- PC control console with 2 free PCI plug-ins (for use by external PCI hardware)
- Stainless steel keyboard
- Safety light curtain
- Milling and engraving spindles
- SK11/SK20 automatic tool change stations
- Minimum quantity lubrication or CoolMin cooling system
- Vacuum clamping benches
- Suction device
- 4. Axis e. g. RDH series installation
- pneumatic sliding door
- closed hood attachment

### Setup

- Portal: fixed, bench: mobile

### Dimensioned drawings/dimensions

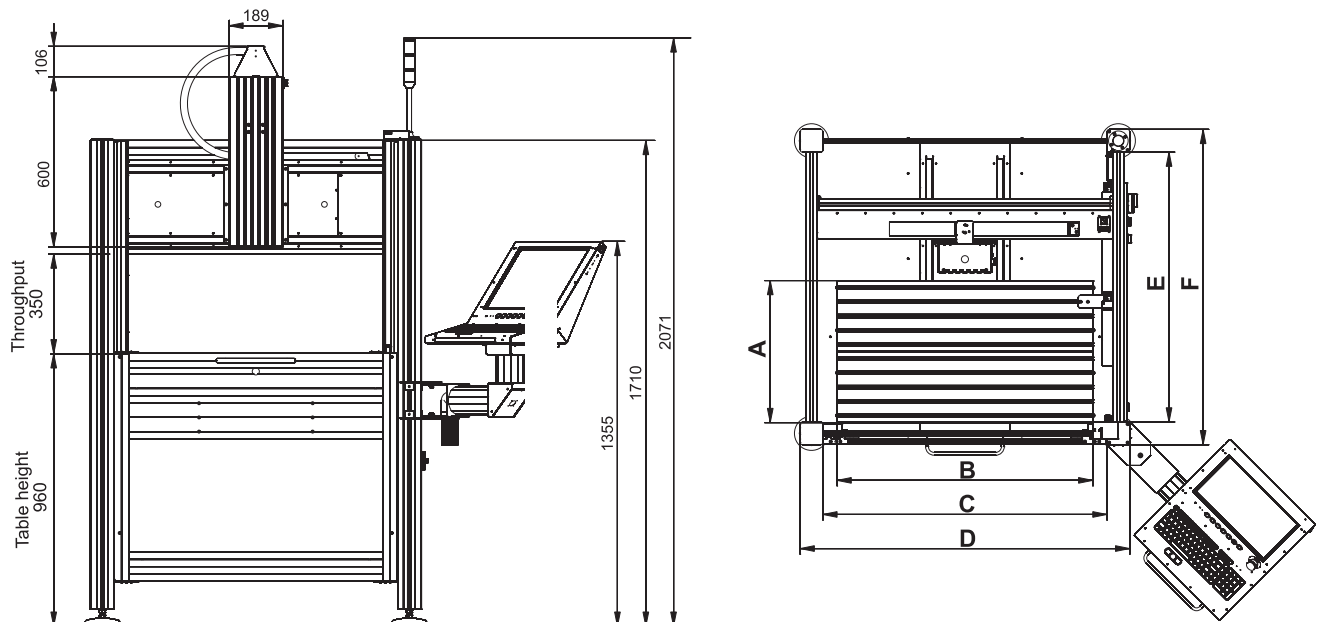

	A	B	C	D	E	F
<b>EuroMod MP30</b>	350	900	1000	1160	640	800
<b>EuroMod MP45</b>	500	900	1000	1160	950	1110
<b>EuroMod MP65</b>	700	1200	1200	1480	1350	1510



CSPRO3D - 808 Rue de la Bergeresse 41600 - Olivet  
 France Tel : 02 38 47 29 42 - 07 68 43 10 37  
 Site Web : [www.cspro3d.com](http://www.cspro3d.com) - Mail : [contact@cspro3d.com](mailto:contact@cspro3d.com)